

Adaptor TNC plug to SMA jack

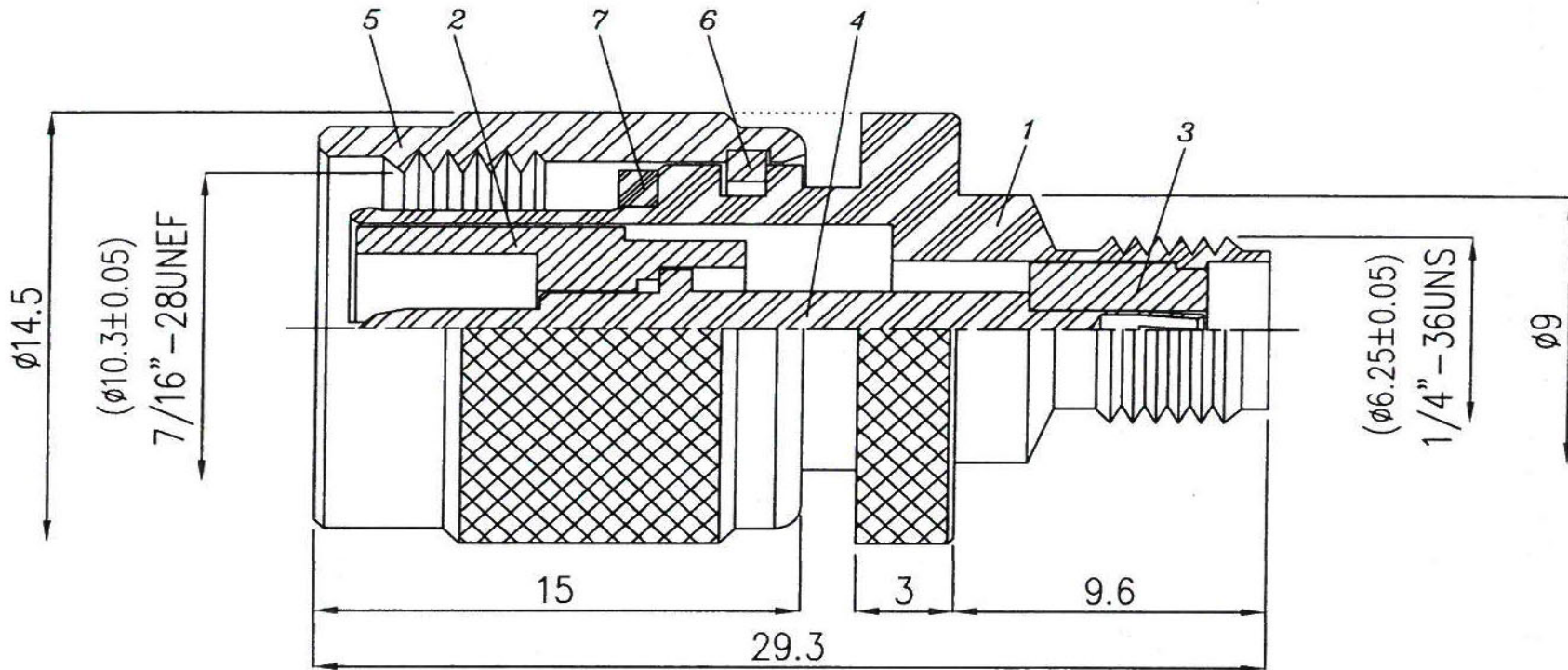

Unit in mm

Tolerances:

| | |
|----------------------|-----------------------|
| 0-0.5mm \pm 0.10mm | 0.5-8mm \pm 0.20mm |
| 8-30mm \pm 0.40mm | 30-120mm \pm 0.50mm |

| NO | DESCRIPTION | Q'TY | MATERIAL | PLATING |
|----|----------------|------|----------|---------|
| 1 | BODY | 1 | BRASS | NICKEL |
| 2 | DIELECTRIC 1 | 1 | PTFE | - |
| 3 | DIELECTRIC 2 | 1 | PTFE | - |
| 4 | CENTER PIN | 1 | BRASS | GOLD |
| 5 | SHELL | 1 | BRASS | NICKEL |
| 6 | RETAINING RING | 1 | BRASS | - |
| 7 | GASKET | 1 | RUBBER | - |

All material in accordance with RoHS + REACH!

Ledino LED LIGHTING
the energy saving company

Ledino Deutschland GmbH
Spitzahornweg 1
14974 Ludwigsfelde / Berlin

Tel. +49 (0)30 7673736-0
Fax +49 (0)30 7673736-40
Email: info@ledino.de

| | | | | | | |
|----------|----------|-------|-------|---------|--------|---------|
| Prep.: | Date: | Rev.: | Date: | Remark: | Prep.: | Check.: |
| J.A. | 29.01.18 | | | | | |
| Check.: | Date: | | | | | |
| Approv.: | | | | | | |

| | |
|---------------------|-----------------|
| Item No.: | T SMA 01 |
| Customer Item No.: | |
| EAN Bar Code: | |
| All rights reserved | Page 1 of 1 |